

ATTENTION

After the first training hour, check all the tightenings and in a particular manner:

- Footboard supports
- Front and rear brake disks
- Wheel rims
- Shock absorber bolt
- Engine bolts and nuts
- Crown

SECTION 1: GENERAL INFORMATION	
Main parts	42
Vehicle identification data.....	42
Instrument panel and controls.....	42
Technical data	43
Electrical diagram	44

SECTION 2: OPERATION AND USE	
Check and maintenance before and after offroad use	46
Fueling	46
Recommended lubricants and liquids	47
Breaking in	47
Startup	48

SECTION 3: MAINTENANCE AND CHECKS	
Gearbox oil	50
Brake pump oil	51
Clutch pump oil	53
Fork oil	54
Air filter	56
Spark plug	57
Front brake	58
Rear brake	59
Liquid coolant	60
Silencer	60
Carburetor	61
Valve petals	61
Checks after cleaning	62
Maintenance schedule	62

SECTION 4: ADJUSTEMENTS	
Adjustment of brake	64
Adjustment of clutch	64
Adjustment of idling speed	65
Adjustment of gas clearance	65
Check and adjustment of steering gear.....	66
Tightening the chain	66
Adjustment of front suspension	67
Positioning of handlebar	67
Adjustment of rear shock absorber	68

SECTION 5: WHAT TO DO IN AN EMERGENCY	
Troubleshooting	70

ALPHABETICAL INDEX	
Index	71

SECTION I

INDEX

Main parts

Vehicle identification data

Instrument panel and controls

Technical data

Electrical diagram

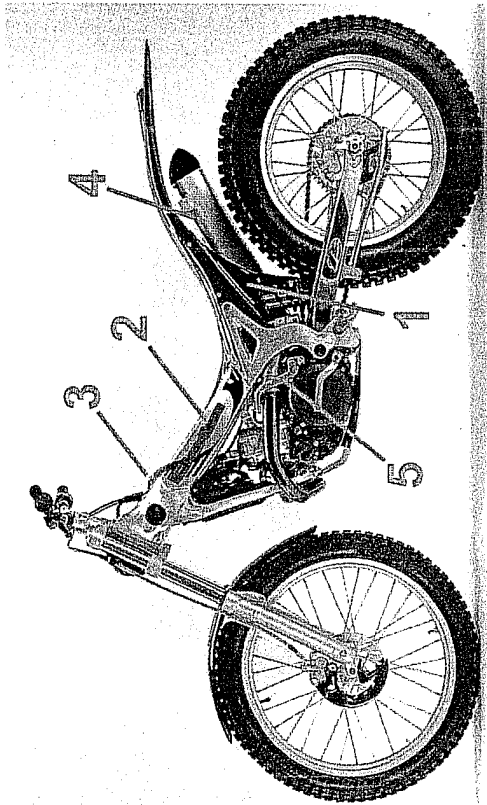

MAIN PARTS

- 1-Air filter
- 2-Fuel tank
- 3-Fuel cap
- 4-Silencer
- 5-Kick starter

VEHICLE IDENTIFICATION DATA

Frame identification
Identification data A are stamped on the right side of the steering gear column.

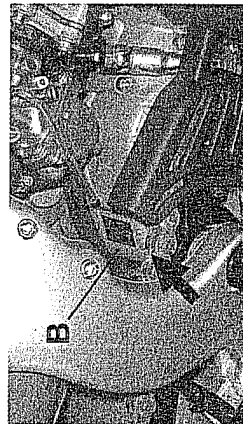
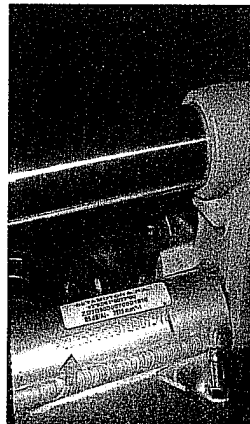

Motor identification
Motor identification data B are stamped as indicated in the picture.

INSTRUMENT PANEL AND CONTROLS

- 1 Clutch lever
- 2 Front brake lever
- 3 Throttle grip

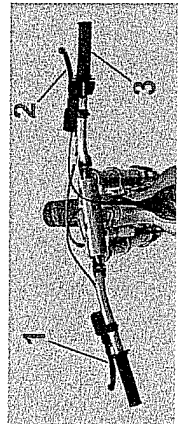

TECHNICAL DATA

- Vehicle weight ready to operate (unfueled)..... 75,5 (kg)
- Dimensions**
- total length..... 1.985 mm
- total width..... 830 mm
- total height..... 1.120 mm
- wheelbase..... 1.315 mm
- saddle height..... 640 mm
- clearance from ground..... 300 mm

- Tyre**
- pressure kg/cm²..... front 0,5 / rear 0,3
- dimensions..... front 2,75-21" (tube type)
- rear 4,00-18" (X11 tubeless)

- Filling capacity**
- fuel tank..... 3,2 (lit)
- including reserve of..... 1 (lit)
- cooling circuit liquid..... 600 (cc)
- engine oil..... 550 (cc)

Front suspension
-hydraulic fork with 38 mm ϕ rods, adjustable in extension, and loading of springs.

- Oil content in shafts:**
- right..... 370cc
- left..... 350cc

Rear suspension
-single-element hydraulic shock absorber with progressive system, adjustable in extension and loading of spring

Front and rear brake
-disk-type with hydraulic control

- Engine**
- type..... BETA6605 ZD3B9T
- number of cylinders..... 1
- bore x stroke..... 72,5x60,5 mm
- displacement (cm³)..... 249,7
- compression ratio..... 11,4:1
- liquid cooled
- electrical digital ignition by magneto flywheel alternator with variable spark advance
- kick-starter
- spark plug..... CHAMPION IN7CC

- Fuel system**
- carburetor..... MIKUNI VM 26-208
- jet..... 150-30 max/min
- operation with unleaded gas/oil fuel mixture:
- synthetic oil..... 1,5%
- mineral oil..... 4%

SECTION 2

INDEX

- Check and maintenance before and after off-road use
- Fueling
- Recommended lubricants and liquids
- Breaking in
- Start up

ELECTRICAL DIAGRAM

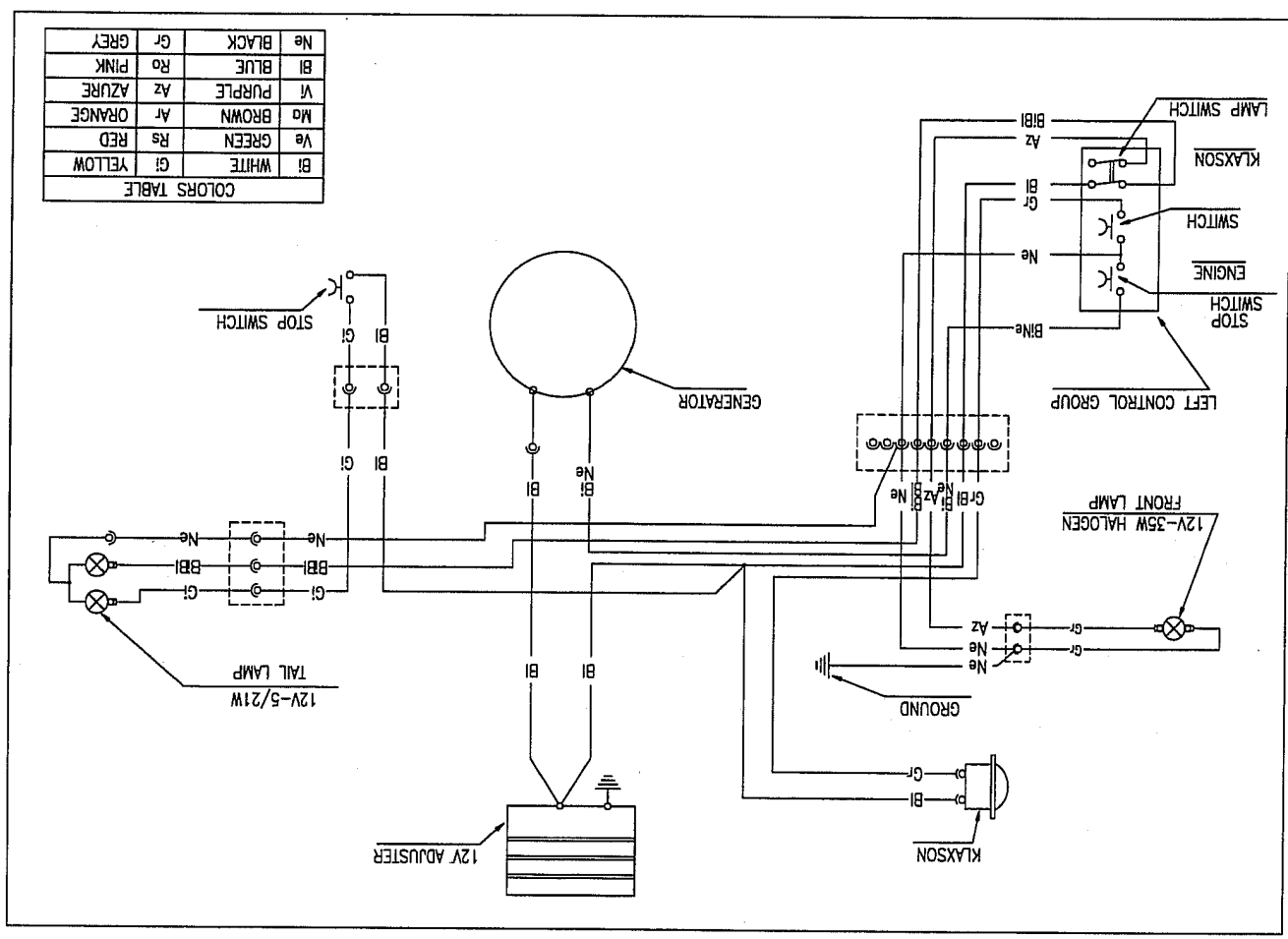

CHECKS AND MAINTENANCE BEFORE AND AFTER OFF-ROAD USE

In order to avoid problems connected to the operation of the vehicle, it is advisable to perform a number of checks and maintenance operations before and after use. Just a few minutes given to these procedures will save you time and money, and will make riding much safer. Proceed as follows:

- TIRES check pressure general condition and thickness of tread
- SPOKES check for correct tension
- NUTS AND BOLTS check completely all bolts and nuts
- CHAIN check tension (20 mm play) and grease if necessary
- AIR FILTER clean filter and wet with oil
- LEVERAGE grease and check nuts and bolts

Note:

Check that you have the vehicle identification documents.
On cold days, warm up the motor by running it at minimum for a few minutes before starting off. Wash the vehicle carefully after every off-road use.

FUELING

Remove cap A.

The fuel tank will hold approximately 3,2 liters, 1 liter of which is reserve.

Use only a mixture of unleaded super grade gas and oil (mineral oil 4%, synthetic oil 1,5 %)

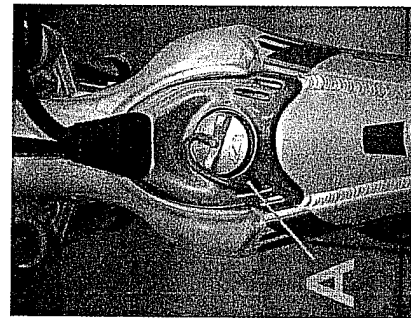

RECOMMENDED LUBRICANTS AND LIQUIDS

For better operation and longer vehicle life, we advise you to use the products listed in the following chart:

TYPE OF PRODUCT	TECHNICAL SPECIFICATION
TRANSMISSION OIL	IP "DUALGRADE 20W/30"
OIL FOR MIXTURE	IP "TOP RACE 2"
BRAKE AND CLUTCH OIL	IP "EF. DOT 5"
FORK OIL	IDEMITSU OJ-RACING-01 or BEL RAY "VC 10 SAE 5"
GREASE FOR JOINTS AND RODS	IP "FL GREASE"
LIQUID COOLANT	IP "ECOBLU"

NOTE:

For substitution, follow attentively the chart.

BREAKING IN

Breaking in takes approximately 10 hours of operation. During this time:

- To ride after having well warmed the engine
- Avoid travel at high speeds
- Change speed often so that the parts will break in uniformly and in a shorter time
- Avoid turning the throttle more than 3/4 of the way.

Warning:

- After the first 5 hours of operation, change the gear oil.
- Always use a mixture of unleaded super grade gas and oil (mineral oil 4%, synthetic oil 1,5 %).
- After the first off-road use, check all of the nuts and bolts.

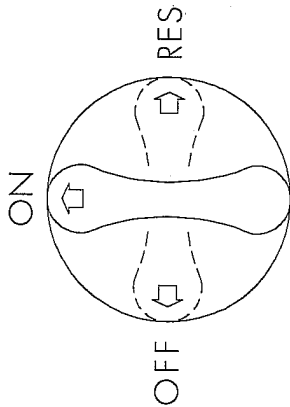

STARTUP

- Open fuel tank valve B
- OFF = closed
- ON = open
- RES = reserve
- Check that the gears are in neutral
- Depress the kick-starter with a sharp movement of the foot and slightly turn the gas control
- Always close the fuel tank valve when the engine is off.

Note:
When the engine is cold, use choke A. Pull the lever, wait a few seconds, and then return the lever to its starting position.

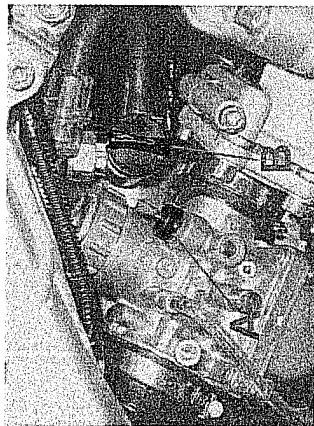

SECTION 3

INDEX

- Gearbox oil
- Brake pump oil
- Clutch pump oil
- Fork oil
- Air filter
- Spark plug
- Front brake
- Rear brake
- Cooling liquid
- Silencer
- Carburetor
- Valve petals
- Checks after cleaning
- Maintenance schedule

GEARBOX OIL

Check

Hold the vehicle vertical to the ground. When engine is cold check the oil level by means of oil window A. Minimum oil level must never be below the level of window A. To restore the oil level, top up by means of oil filler cap B.

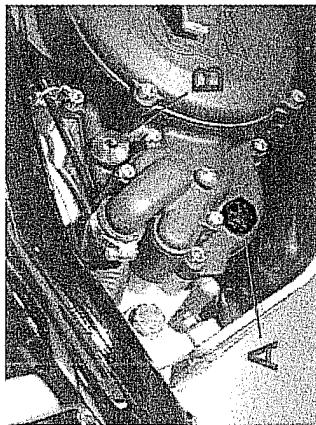

Oil change

The engine must be hot when changing oil:

- Place a container under the engine
- Unscrew the filler cap and oil drain plug C
- Empty the crankcase completely
- Close drain plug C
- Put in the right oil quantity (table on page 43)
- Close the filler cap.

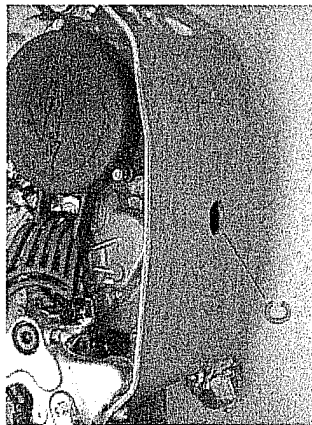

Note:

Change the gearbox oil after the first 5 hours of operation. For subsequent all changes, follow the instructions given on the chart on pag. 62, using the lubricants recommended on pag. 47.

BRAKE PUMP OIL

Front brake

Check the oil level by means of oil window A. Minimum oil level must never be below the level of window A.

To restore the oil level, top up by unscrewing the two screws B, lifting cap C and adding oil.

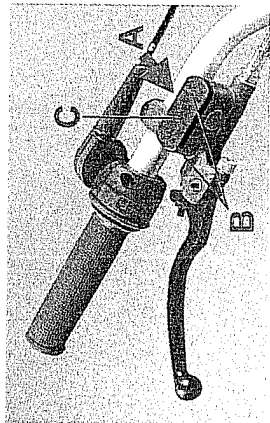

Rear brake

To check the oil level remove the rear cover by unscrewing its 5 relevant screws and the 2 upper screws of the air filter cover, then check oil level by means of oil container E.

Oil level must never be below the minimum level mark on container E. To restore the oil level, top up by means of oil filler cap F.

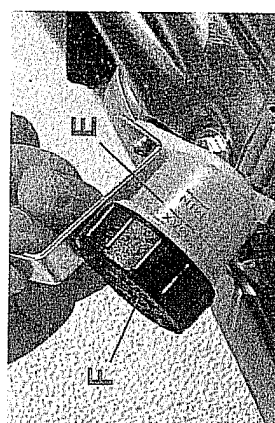
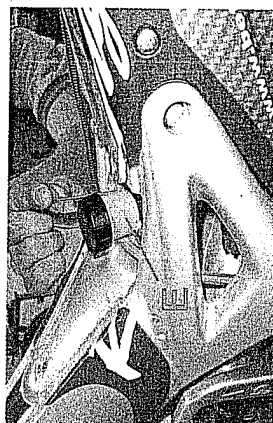

Warning:

If the lever feels soft, there may be an air bubble in the circuit. Apply to your dealer immediately.

Note:

For oil changes, follow the instructions given on the chart on pag. 62, using the lubricants recommended on pag. 47.

Bleeding of front brake
To bleed air from the front brake circuit, proceed as follows:

- Remove the rubber cap A from valve B
- Open the oil sump cap
- Insert one end of a tube into valve B and the other end into a container
- Unscrew the valve and pump with the brake lever until obtaining a continuous outflow of oil with no air bubbles. During this procedure, you must continuously top up the brake pump tank to replace the oil that is removed
- Tighten the valve and replace the rubber cap
- Remove the tube.



Bleeding of rear brake
To bleed air from the rear brake circuit, proceed as follows:

- Remove rubber cap C
- Open the oil sump cap
- Insert one end of a tube into valve D and the other end into a container
- Unscrew the valve and pump with the brake lever until obtaining a continuous outflow of oil with no air bubbles. During this procedure, you must continuously top up the brake pump tank to replace the oil that is removed
- Tighten the valve and replace the rubber cap
- Remove the tube.

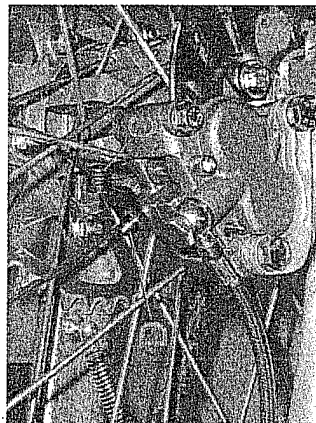

Note:
Handle the hydraulic oil very carefully. It is corrosive, and will irreparably damage painted or plastic parts of the motorcycle upon contact.

CLUTCH PUMP OIL

Check the oil level. The oil level must never be below half the tank capacity. To restore the oil level, top up by unscrewing the two screws A, lifting cap B and adding oil.

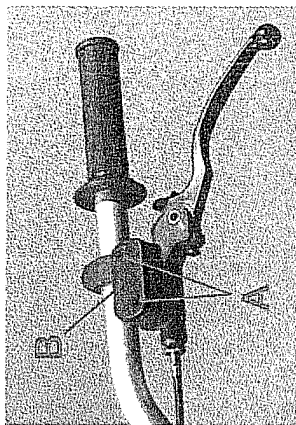

Note:
For oil changes, follow the instructions given on the chart on pag. 62, using the lubricants recommended on pag. 47

Bleeding of clutch
To bleed air from the clutch circuit, proceed as follows:

- Remove the rubber cap from valve C
- Open the oil sump cap
- Insert one end of a tube into valve D and the other end into a container
- Unscrew the valve and pump with the clutch lever until obtaining a continuous outflow of oil with no air bubbles. During this procedure, you must continuously top up the clutch pump tank to replace the oil that is removed
- Tighten the valve and replace the rubber cap
- Remove the tube.

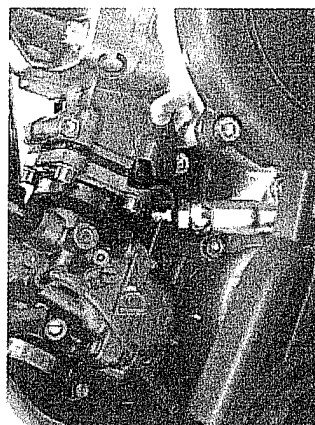

Note:
Handle the hydraulic oil very carefully. It is corrosive, and will irreparably damage painted or plastic parts of the motorcycle upon contact.

FORK OIL

Right shaft

To replace the oil, proceed as follows:

- 1) Remove the front wheel
- 2) Remove the handlebar (see pag. 65)
- 3) Loosen left shaft lock screw A and take off the slider
- 4) Unscrew upper plug
- 5) Unscrew fixing lock nut and take off the plug
- 6) Unscrew the fixing screw of the cartridge positioned under the slider, and extract the cartridge
- 7) Empty the fork leg and the cartridge, the drain all the inside oil
- 8) Fit again the cartridge on the slider tightening the fixing screw, then refill oil (OJ01) in the cartridge up to the level indicated in the figure (with fork in the fully compressed position)
- 9) Fit again the plug on the rod, tighten the lock nut and, extending the fork leg, screw the plug on the shaft
- 10) Fit again the fork

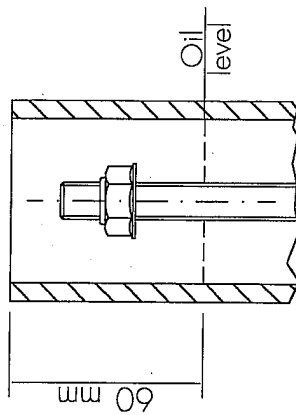
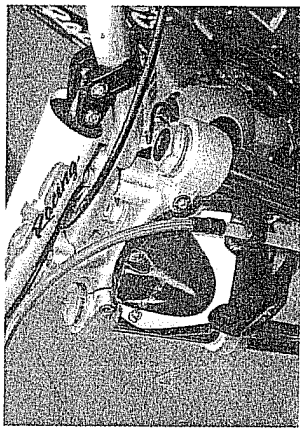

Left shaft

To replace the oil, proceed as follows:

- 1) Remove the front wheel
- 2) Remove the handlebar (see pag. 65)
- 3) Unloose the shaft lock screw A
- 4) Unscrew slider plug
- 5) Remove the spring and totally empty the oil
- 6) Reset the spring and fill with oil (OJ01) up to the level indicated in figure

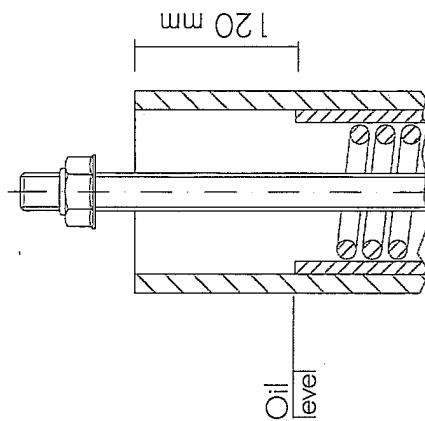
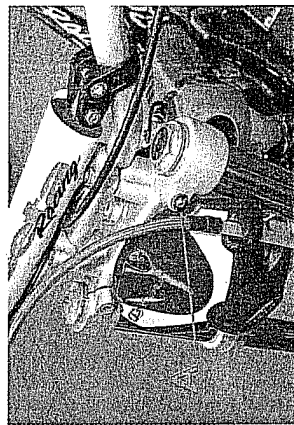

Note:

For all changes, follow the instructions given on the chart on pag. 62, using the lubricants recommended on pag. 47. Check regularly and clean thoroughly removing any dirt on dust cover and also check the rubber seal to ensure a good seal.

AIR FILTER

To access the filter you must remove the plastic cover by unscrewing its 3 relevant screws and then proceed as follows:

- Remove filter B by unscrewing filter fastener cover fixing screws
- Wash the filter with gasoline
- Dry the filter
- Wet the filter with filter oil, removing any excess oil so that there is no dripping
- If necessary, clean the inside of the filter box
- Reassemble, paying attention to the exact hermetic closing of rubber gasket.

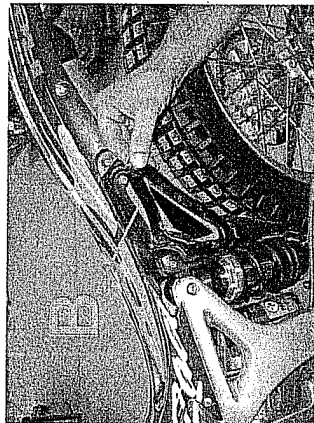
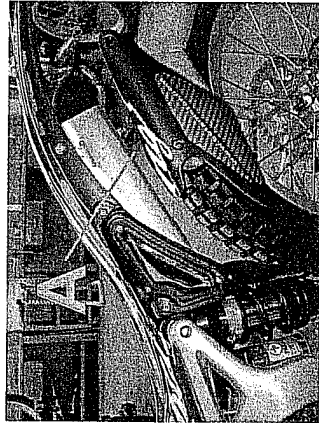

Note:

- If the filter is very dirty, wash it first with gasoline and then with water and shampoo.
- If the filter is damaged, replace it immediately.

Warning:

After every intervention, check that nothing has been left inside the filter box.

Clean the filter every time the vehicle is used cross-country.

SPARK PLUG

Keeping the spark plug in good condition will reduce fuel consumption and increase engine performance.

To perform the check, simply slide off the electrical connection tube and unscrew the spark plug.

Examine the distance between the electrodes with a feeler. This distance should be from 0.5 to 0.6 mm. If it is not, it may be corrected by bending the earth electrode.

Check as well that there are no cracks in the insulation or corroded electrodes. If so, replace immediately.

Observe the chart on page 62 when performing the check.

When replacing the spark plug, screw it in by hand until it stops, then tighten with a wrench.

Note:

- The use of low-quality oil will cause an increase in carbon deposits. We therefore advise the use of "IP TOP RACE 2" oil.
- Always use CHAMPION N7YCC spark plugs.

FRONT BRAKE

Check

To check the front brake for wear, simply observe the caliper from the front, where it is possible to see the ends of the two pads. These pads should have at least a 2 mm layer of lining. If this layer is thinner than 2 mm, replace the pads immediately.

Note:

Observe the times given on the chart on pag. 62 when performing the check.

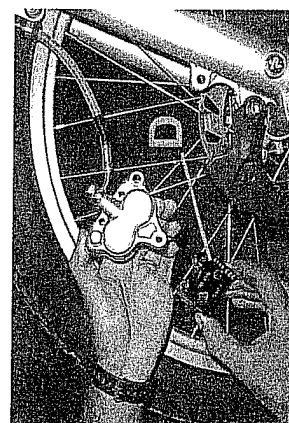
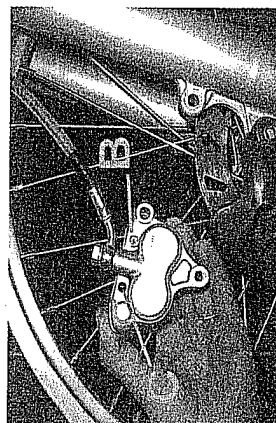
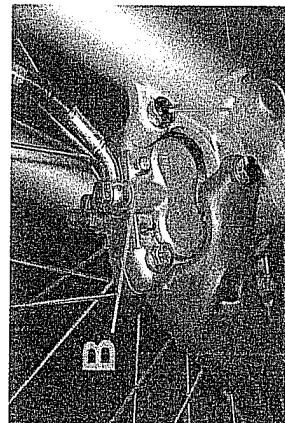
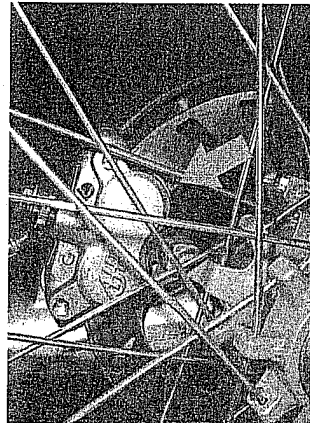

Replacement

To replace the pads, proceed as follows:

- Disassemble the disk cover and the caliper by unscrewing the two screws A and releasing the screw B
- Slide the split pin C
- Unscrew the screw B
- Remove the pads D and replace them
- To reassemble, proceed in the reverse order.

Note:

To avoid braking problems, pay particular attention to the correct reassembly of the split pins.

If the brake disk is removed, apply Loctite to the screws when reassembling.

REAR BRAKE

Check

To check the rear brake for wear, simply observe the caliper from the rear, where it is possible to see the ends of the two pads. These pads should have at least a 2 mm layer of lining. If this layer is thinner than 2 mm, replace the pads immediately.

Note: Observe the times given on the chart on pag. 62 when performing the check.

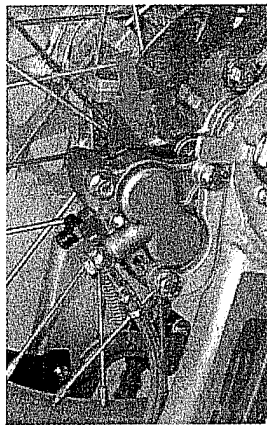

Replacement

To replace the pads, see the front brake replacement procedure.

Note:

To avoid braking problems, pay particular attention to the correct reassembly of the split pins.

If the brake disk is removed, apply Loctite to the screws when reassembling.

LIQUID COOLANT

The level check must be performed with the engine cold, as follows:

- Remove plastic grid D
- Unscrew cap A and check the level of the liquid
- If the level is close to the bottom of pipe proceed to add liquid

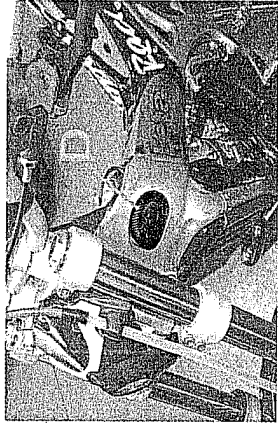

Circuit capacity is indicated in the table on pag. 43. Use the liquids recommended on the table on pag. 47.

WARNING:

To avoid burns, never unscrew the radiator filler cap when the engine is hot.

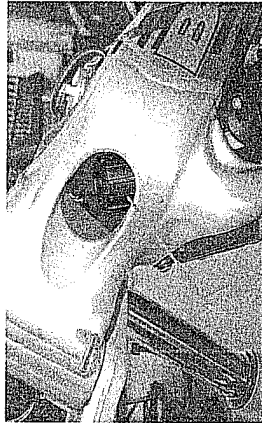

SILENCER

If an increase in exhaust noise is noted, check the silencer.

Proceed as follows:

- Unscrew the two screws B
- Remove end piece C
- With a metal hook, remove all of the fiber wool (if it is deteriorated)
- Fill the silencer with new fiber wool
- To reassemble, proceed in the reverse order.



CARBURETOR

To ensure excellent carburetor performance, the carburetor must be cleaned thoroughly after every use of the motorcycle.

After having removed tank B, check the correct position of the float, making sure that float support plate A is parallel to the plane of the carburetor, as shown in the figure. Check the cleanliness of the jets.

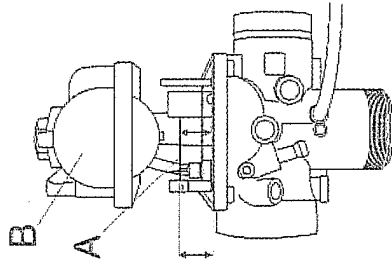

VALVE PETALS

We recommend to check the valve petals as follows after every 40 hours of use:

- Check that flaps A show no signs of breakage.
- Check that flaps A close perfectly on valve body B.

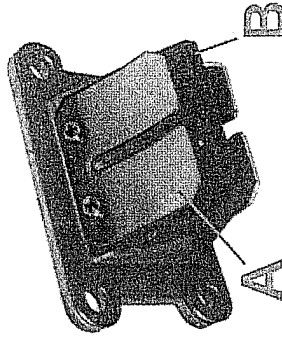

CHECKS AFTER CLEANING

After cleaning the motorcycle, it is good practice to check:

- Clean the air filter (proceed as described on pag.56)
- Remove the flywheel cover to eliminate any water that may have entered.
- If ignition is disassembled and reassembled, check the position of the stator marked by an indicator on the plate and by a corresponding marker on a half-casing fastening support.
- Disassemble the carburetor tank (proceed as described on pag.61) to eliminate any water that may have entered.
- Grease the chain.

MAINTENANCE SCHEDULE

CHECKS (C) REPLACEMENT (R) CLEANING (CL)	SEE PAG.	EVERY OUT	EVERY 20 HOURS	EVERY 40 HOURS	EVERY 60 HOURS	EVERY 100 HOURS	
SPARK PLUG	57			C	R		
AIR FILTER	56	CL				R	
ADJUSTMENT OF IDLING SPEED	65		C			C	
GEARBOX OIL	50			C		R	
BRAKE AND CLUTCH PUMP OIL	51-53			C			
FORK OIL	54-55	First oil change should be after 1 month or 30 hours riding and successfully one time per year					
STEERING GEAR PLAY	65				C		
BRAKES	64	C					
TIRES	43			C			
PISTON	/					C	
FLAPS	61			C			
LIQUID COOLANT	60			C			

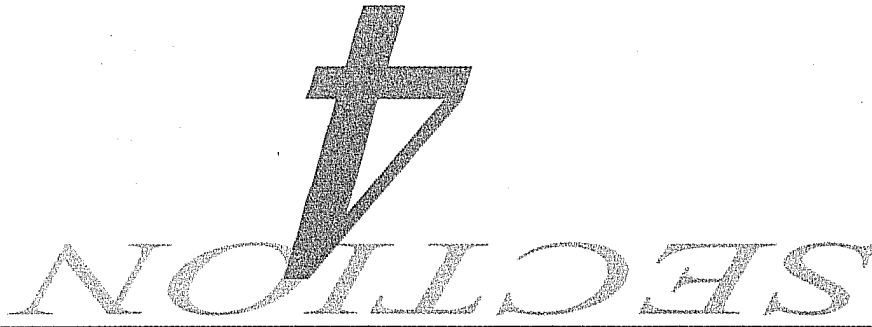

INDEX

- Adjustment of brakes
- Adjustment of clutch
- Adjustment of idling speed
- Adjustment of gas clearance
- Check and adjustment of steering gear
- Tightening the chain
- Adjustment of front suspension
- Positioning of handlebar
- Adjustment of rear shock absorber

ADJUSTMENT OF BRAKES

Front brake

The front brake is disk type with hydraulic control, and therefore requires no adjustment. If you want to adjust the position of the lever, use register A.

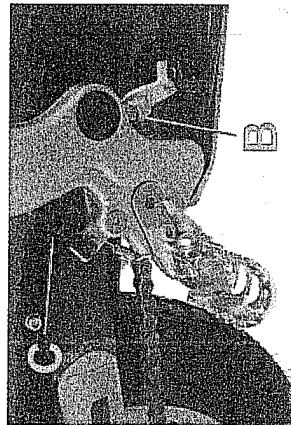
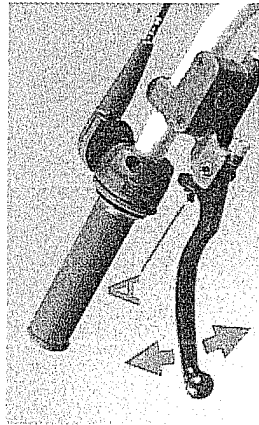

Rear brake

The rear brake is disk type with hydraulic control. You may adjust pedal height by means of registers B and C.

ADJUSTMENT OF CLUTCH

Generally, the only operation that is performed on the clutch is adjustment of the position of lever E. To do this, use register D.

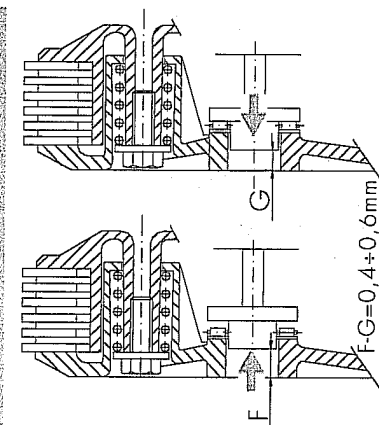
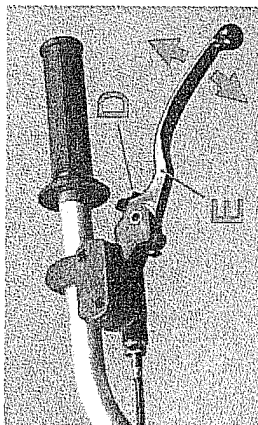

Note:

The clutch must have a play of between 0.4 mm and 0.6 mm. Therefore, proceed as follows when replacing disks:

- Reassemble the clutch without the outer cover
- Send the control rod to end of travel by pushing from the pressure plate and measure distance F
- Operate the clutch lever until the control rod activates the pressure plate. Measure distance G and check that there is difference of approximately 0.4-0.6mm.

ADJUSTMENT OF IDLING SPEED

In order to perform this operation correctly, we advise you to do it when the engine is hot, connecting an electric revolution counter to the spark plug wire. Then use a screwdriver on register screw A to calibrate the minimum (1000 rpm).

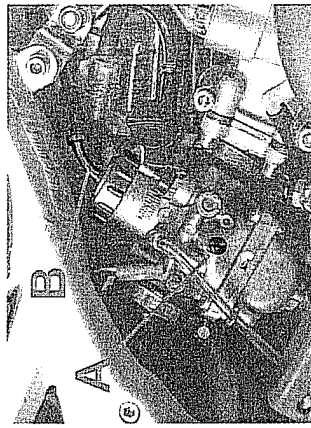

ADJUSTMENT OF GAS CLEARANCE

Whenever the accelerator shows unloaded travel exceeding 3 mm, measured from the edge of the handle, you should adjust it by means of carburetor register B.

CHECK AND ADJUSTMENT OF STEERING GEAR

Periodically check the play in the steering sleeve by moving the fork back and forth as shown in the figure. Whenever you feel play, adjust as described below:

- Unscrew the 4 screws C
 - Remove handlebar D
 - Loosen nut E
 - Take up the play by means of ring nut F.
- For reassembly, proceed in the reverse order.

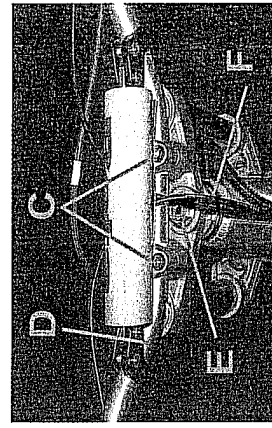
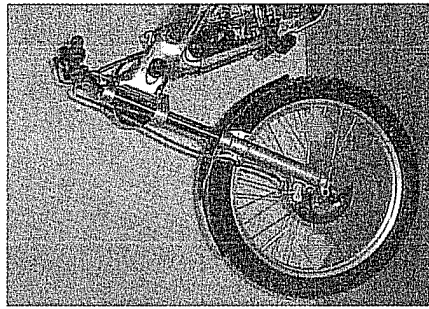

TIGHTENING THE CHAIN

Checking the drive chain periodically to ensure longer chain life. Always keep it lubricated and clean of deposited dirt. If play exceeds 20 mm, tighten the chain as follows:

- Loosen nut A
- Adjust lever B
- Adjust the same lever on the opposite side, bringing it to the same position
- Check wheel alignment
- Tighten and block nut A.

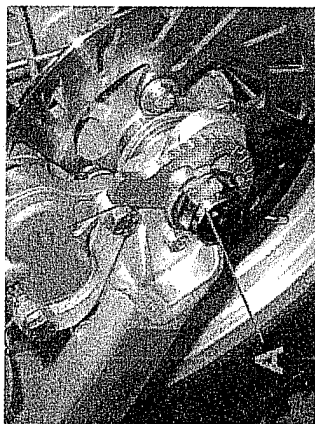
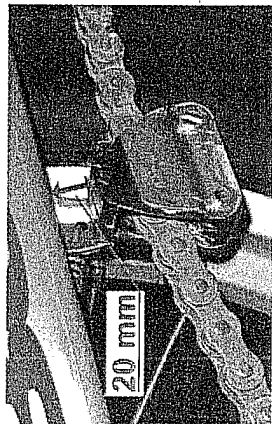

ADJUSTMENT OF FRONT SUSPENSION

Fork

- For a more active "quicker" suspension setting, totally unscrew regulation knob B compared to the std. position
- For a more controlled "slower" suspension setting, preload spring for about 4-5 turns on the adjusting screw A and turning the knob B by 15 clicks from the fully opened position, which is in the middle of the adjustment.
- Rider weight. According to the riders weight, use the following settings:

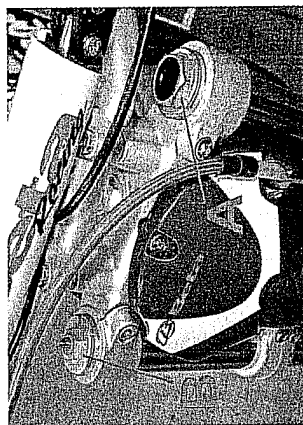

RIDER WEIGHT (kg)	SPRING PRELOAD
weight > 80	+ 10 turns
75 < weight < 80	+ 5 turns
weight < 70	0

In the event of any malfunction, contact our authorised customer service network.

ADJUSTMENT OF REAR SHOCK ABSORBER
Adjustment of spring load

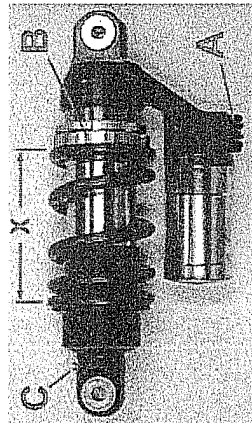

- For a more active "quicker" suspension setting, close compression regulation knob A
- For a more controlled "slower" suspension setting, open compression regulation knob and close extension brake (screw C)
- Rider weight. According to the riders weight, use the following settings:

RIDER WEIGHT (kg)	SPRING PRELOAD X (act on two ring nuts B)	EXTENSION REGULATION	COMPRESSION REGULATION
60/70	113 mm	from all open position close 1/2 turn	all open
70/80	111 mm	from all open position close 1 turn	from all open position close 6 clicks
>80	109 mm	from all open position close 1 1/2 turn	from all open position close 10 clicks

- Cleaning periodically the rebound rubber as follow: raise rebound rubber using a little screwdriver and blow with compressed air in the spring spacer milling
- Always check the top and bottom bolts are tight.

In the event of any malfunction, contact our authorised customer service network.

SECTION

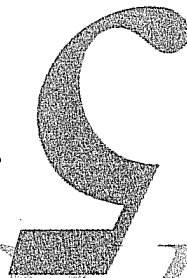

PROBLEM	CAUSE	REMEDY
The engine doesn't start	-Fuel system (tubes, fuel tank, valve) is blocked	Clean the system
	-Air filter is very dirty	Proceed as indicated on page 56
	-No current arriving at spark plug	Clean or replace spark plug. If the problem persists, consult one of our Authorized Dealers
	-Engine is flooded	With gas completely open, continue trying to start engine for a few moments. If engine still doesn't start, remove the spark plug and dry it off.
Engine misfires	-Spark plug has irregular electrode distance	Restore correct distance
	-Spark plug is dirty	Clean or replace
Piston knocks	-Ignition too early	Check phases
	-Carbon deposits inside cylinder or on spark plug	Consult one of our Authorized Dealers
	-Silencer partially obstructed	Consult one of our Authorized Dealers
Engine overheats and loses power	-Exhaust clearance partially obstructed	Consult one of our Authorized Dealers
	-Mix too lean	Jet may be partially obstructed
	-Delayed ignition	Check phases
	-Worn pads	Proceed as indicated on page 58
Weak front brake	-Air or moisture in hydraulic circuit	Proceed as indicated on page 52
	-Worn pads	Proceed as indicated on page 58
Weak rear brake	-Air or moisture in hydraulic circuit	Proceed as indicated on page 52

Adjustment of brakes	64
Adjustment of clutch	64
Adjustment of front suspension	67
Adjustment of gas clearance	65
Adjustment of handlebar	67
Adjustment of idling speed	65
Air filter	56
Bleeding of brakes	52
Bleeding of clutch	53
Brakes: front brake check and replacement	58
Brakes: rear brake check and replacement	58
Breaking in	47
Carburetor	61
Checks after cleaning	62
Checks and maintenance before and after off-road use	46
Electrical diagram	44
Front suspension	67
Fueling	46
Instrument panel and controls	42
Liquid coolant	60
Lubricants and liquids	47
Main parts	42
Maintenance schedule	62
Oil gearbox: check and change	50
Oil brake pump	51
Oil clutch pump	53
Oil fork: right shaft	54
Oil fork: left shaft	55
Rear shock absorber	68
Silencer	60
Spark plug	57
Startup	48
Steering gear: check and adjustment	65
Technical data	43
Tightening the chain	60
Troubleshooting	60
Valve petals	61
Vehicle identification data: motor and frame identification	42

